



RECESSED DOOR TO RECEIVE DRYWALL Model RDW

DATE



KARP ASSOCIATES, INC.
260 Spagnoli Road Melville, NY 11747
(631) 768-8300 - Phone
(631) 768-8350 - Fax

SPECIFICATIONS

GENERAL SCOPE:

Access doors shall be Karp Type RDW as manufactured by Karp Associates, Inc., Melville, N.Y.
Sizes shall be as indicated on the drawings.

CONSTRUCTION:

1. Frame shall be 16 gauge steel and doors shall be 16 gauge steel.
2. Door shall be recessed 0.625".
3. Trim shall be galvanized steel dry wall bead.
4. Hinge shall be concealed pivoting rod type.
5. Locks shall be flush and screwdriver operated with cam and studs, or shall be key operated cylinder lock with automatic dust shutter.
6. Finish shall be prime coat of rust inhibitive electrostatic powder, baked white enamel.

STANDARD SIZES

DOOR SIZE H X W (IN.)	WALL/CEILING OPENING (IN.)	NUMBER OF LATCHES	SHIP WT. (LBS.)
12 x 12	12 1/8 x 12 1/8	1	7.4
18 x 18	18 1/8 x 18 1/8	2	12.8
24 x 12	24 1/8 x 12 1/8	2	12.5
24 x 24	24 1/8 x 24 1/8	4	19.4
36 x 24	36 1/8 x 24 1/8	5	29.0

PROJECT DATA

Project Name:

Architect:

Contractor:

Agent/Customer Name:

Tagging Instructions:

Special Instructions:

PROJECT SCHEDULE

Qty.	H	W	No. of Latches	Finish	Remarks

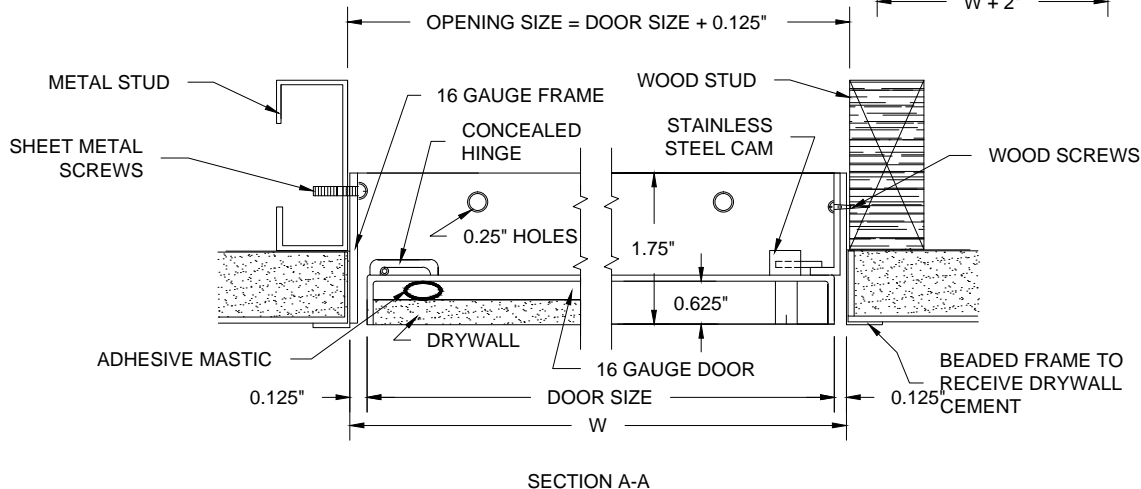
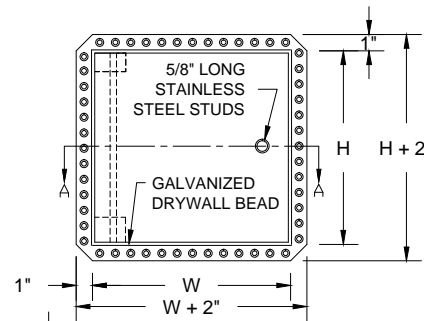

Made with Union Labor