

# REGULAR ARM & TOP JAMB

## TEMPLATE INSTRUCTIONS

5400 Series Non Hold Open Door Closers

### Regular Arm - Installation Instructions

- Select hand of door and degree of door opening.
- Fold template on the corresponding line for desired degree of door opening and hand.
- Match this line with the hinge edge of door and attach template to door.
- Be sure frame line on template lines up with the bottom edge of frame face.
- Mark, prep and drill/tap 1/4" - 20 holes for closer body and jamb shoe mounting screws.

### Top Jamb Arm - Installation Instructions

- Select hand of door and degree of door opening.
- Separate template sections "A" and "B".
- Fold template on the corresponding line for desired degree and hand.
- Match this line with the hinge edge of door and attach template to door.
- Be sure "Frame" line on template lines up with the top edge of the door.
- Using a square, project "Closer Projection Line" on section "A" of template onto frame and use to align and attach section "B".
- Be sure to align bottom edge of section "B" with edge of frame.
- Mark, prep and drill/tap 1/4" - 20 holes for connecting rod shoe and closer body mounting screws.

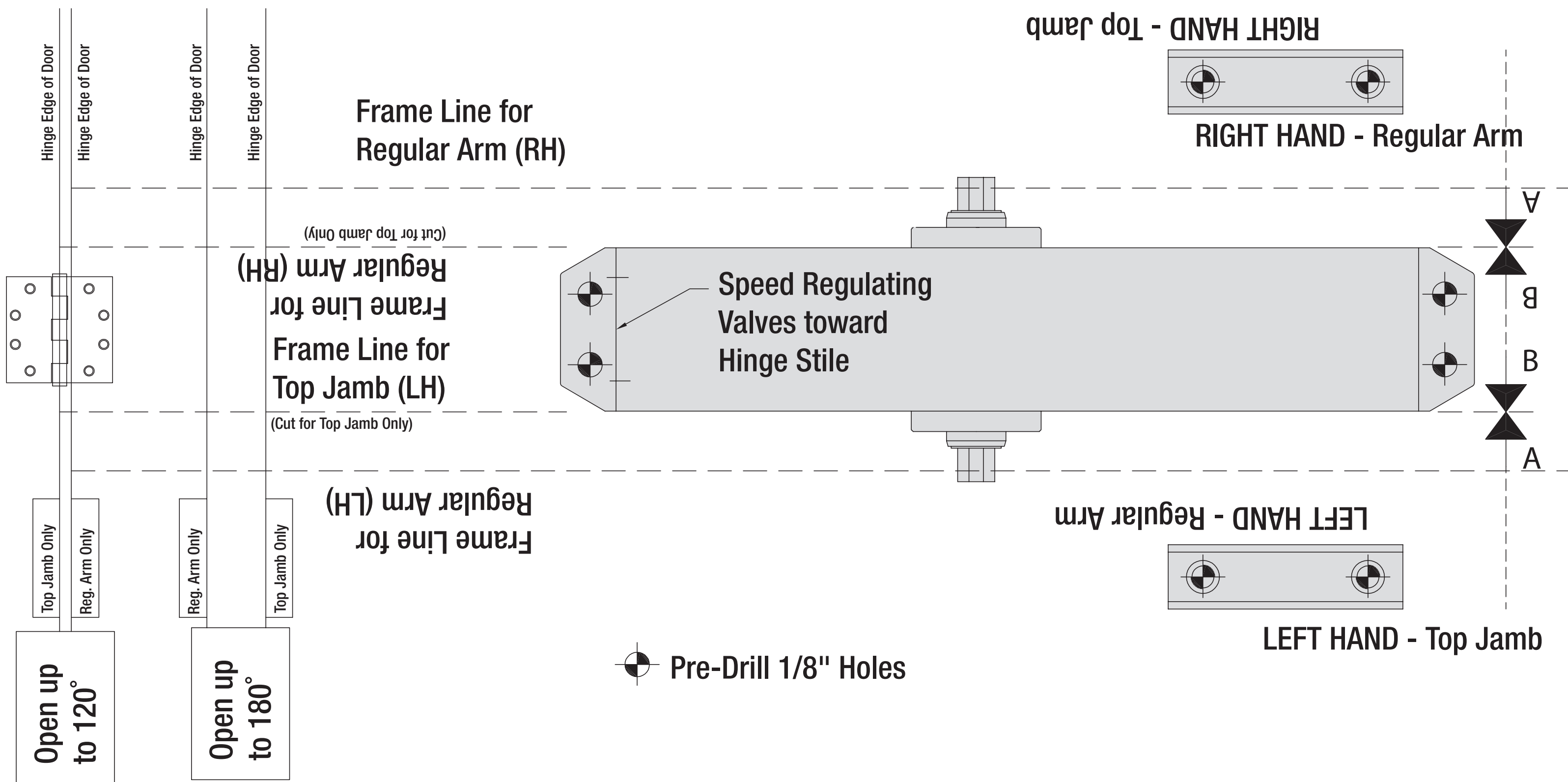

HAGER COMPANIES 139 Victor Street, St. Louis, MO 63104 • (800) 325-9995 • Fax (800) 782-0149

# PARALLEL ARM

## TEMPLATE INSTRUCTIONS

5400 Series Non Hold Open Door Closers

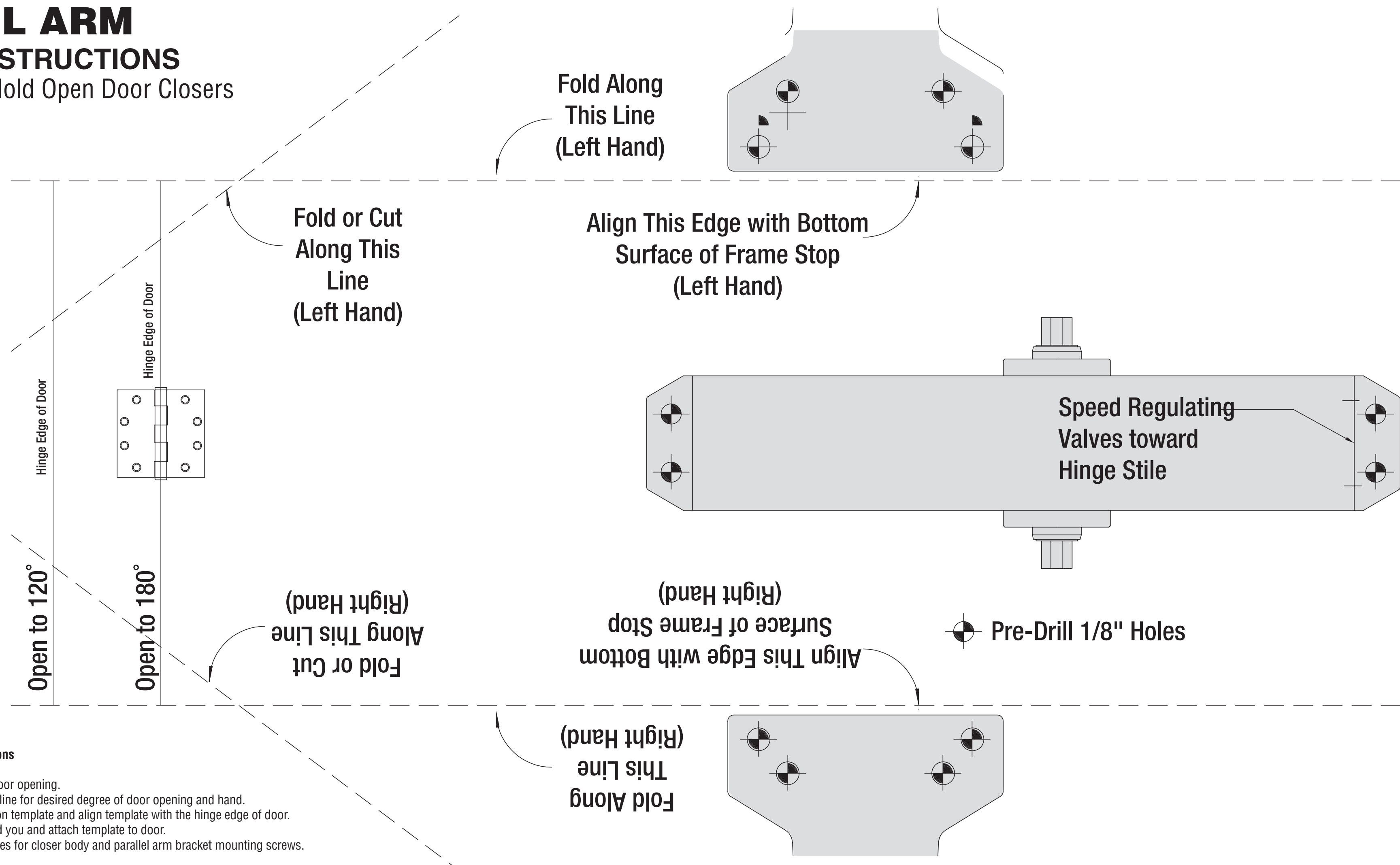

### Parallel Arm - Installation Instructions

- Select hand of door and degree of door opening.
- Fold template on the corresponding line for desired degree of door opening and hand.
- Fold or cut upper corner illustrated on template and align template with the hinge edge of door.
- At the "Frame Stop Line" fold toward you and attach template to door.
- Mark, prep and drill/tap 1/4" - 20 holes for closer body and parallel arm bracket mounting screws.



HAGER COMPANIES 139 Victor Street, St. Louis, MO 63104 • (800) 325-9995 • Fax (800) 782-0149