

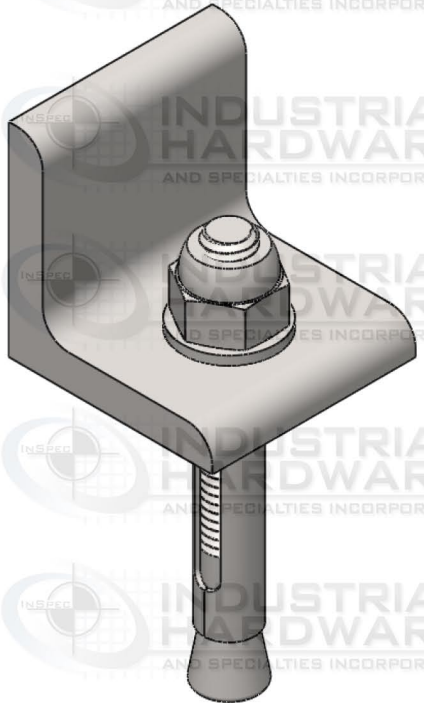

ZONE		REV.	REVISIONS	DATE	APPROVED
			DESCRIPTION		

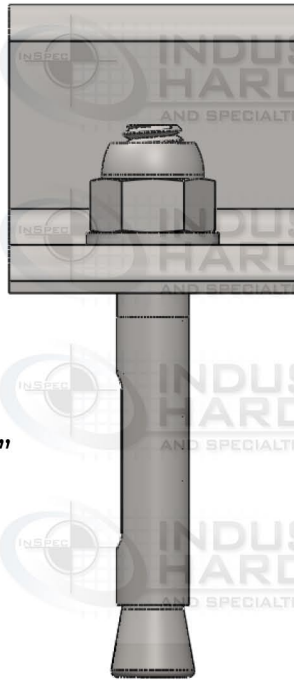
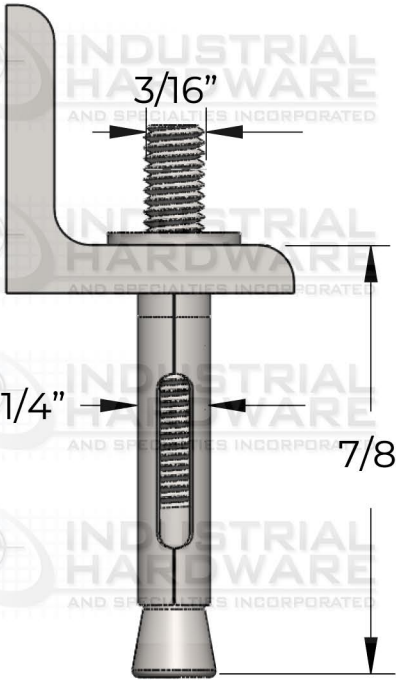
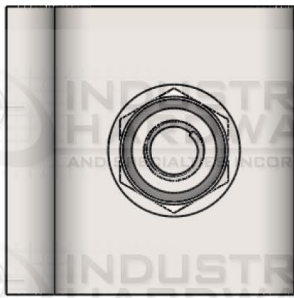

**PROPRIETARY AND CONFIDENTIAL**

THIS DRAWING AND IT'S CONTENT IS THE SOLE PROPERTY OF INDUSTRIAL HARDWARE & SPECIALTIES, INCORPORATED.

ANY REPRODUCTION IN PART OR AS A WHOLE WITHOUT THE WRITTEN PERMISSION OF INDUSTRIAL HARDWARE & SPECIALTIES, INC. IS STRICTLY PROHIBITED. INSPEC AND TOSPEC INDICIA ARE REGISTERED AND PROTECTED TRADEMARKS WITH THE UNITED STATES PATENT & TRADEMARK OFFICE. MODIFICATION, USE OR REMOVAL WITHOUT WRITTEN AUTHORIZATION WILL BE DEEMED A INTENTIONAL VIOLATION OF COPYRIGHT PROTECTIONS.

		DIMENSIONS ARE IN INCHES TOLERANCES: FRACTIONAL $\pm 1/64"$ ANGULAR: MACH $\pm 1^\circ$ BEND $\pm 1^\circ$ TWO PLACE DECIMAL $\pm .01"$ THREE PLACE DECIMAL $\pm .005"$ CONCENTRICITY T.I.R. = $.005"$		NAME	DATE	 <p><b>INDUSTRIAL HARDWARE</b> AND SPECIALTIES INCORPORATED</p> <p>17-B Kentucky Avenue Paterson, New Jersey 07503 T: 973-684-4010 F: 973-684-3095 e-mail: sales@industrialhardware.com www.industrialhardware.com</p>
		MATERIAL <b>Steel</b>		DRAWN		
		FINISH <b>Zinc CR+3 (RoHS)</b>		CHECKED		
NEXT ASSY		USED ON		ENG APPR.		
APPLICATION		DO NOT SCALE DRAWING		MFG APPR.		
				Q.A.		
				COMMENTS:		
				SIZE DWG. NO.	<b>A</b> 20A-1D04A	
				SCALE: 1:2	WEIGHT:	
				SHEET 1 OF 1		