

Key-Locking Internal Locking

REVISIONS		DATE	APPROVED
ZONE	REV.	DESCRIPTION	

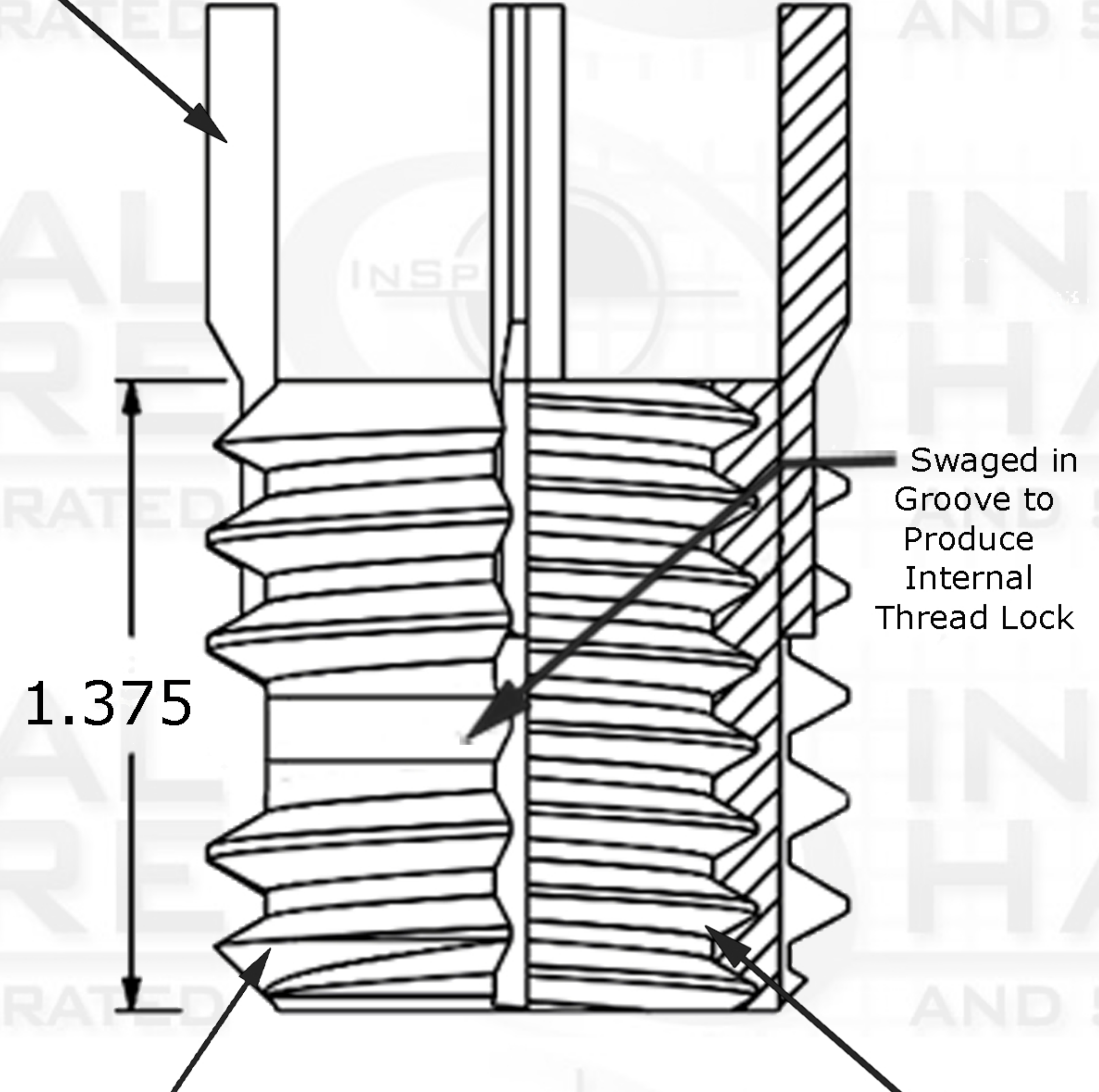

Key



1.375

External Thread Pitch

1-1/4-12

Internal Thread Pitch

7/8-14

Suggested Drill Bit Size



1.1875 (1-3/16)

PROPRIETARY AND CONFIDENTIAL

THIS DRAWING AND IT'S CONTENT IS THE SOLE PROPERTY OF INDUSTRIAL HARDWARE & SPECIALTIES,INC.. ANY REPRODUCTION IN PART OR AS A WHOLE WITHOUT THE WRITTEN PERMISSION OF INDUSTRIAL HARDWARE & SPECIALTIES,INC. IS STRICTLY PROHIBITED.

		Internal		NAME	DATE
		TH. STANDARD : ANSI/ASME	DRAWN		
		ACRONYM: UNF	CHECKED		
		ROTATION: Right-Hand	ENG APPR.		
		External	MFG APPR.		
		TH. STANDARD : ANSI/ASME	Q.A.		
		ACRONYM: UNF			
		ROTATION: Right-Hand			
		MATERIAL FINISH			
		Stainless Steel Type A286	COMMENTS:		
NEXT ASSY	USED ON	PART NUMBER			
		35L8C-7TH4-087-03			
APPLICATION		DO NOT SCALE DRAWING			



17-B KENTUCKY AVENUE
 PATERSON, NEW JERSEY 07503
 TEL: 973-684-4010 FAX: 973-684-3095
 email: TechSupport@industrialhardware.com
 www.industrialhardware.com

SIZE	DWG. NO.	REV.
A		
SCALE:1:8	WEIGHT:	SHEET 1 OF 1