

Key-Locking Non-Locking

ZONE		REV.	REVISIONS	DATE	APPROVED
			DESCRIPTION		

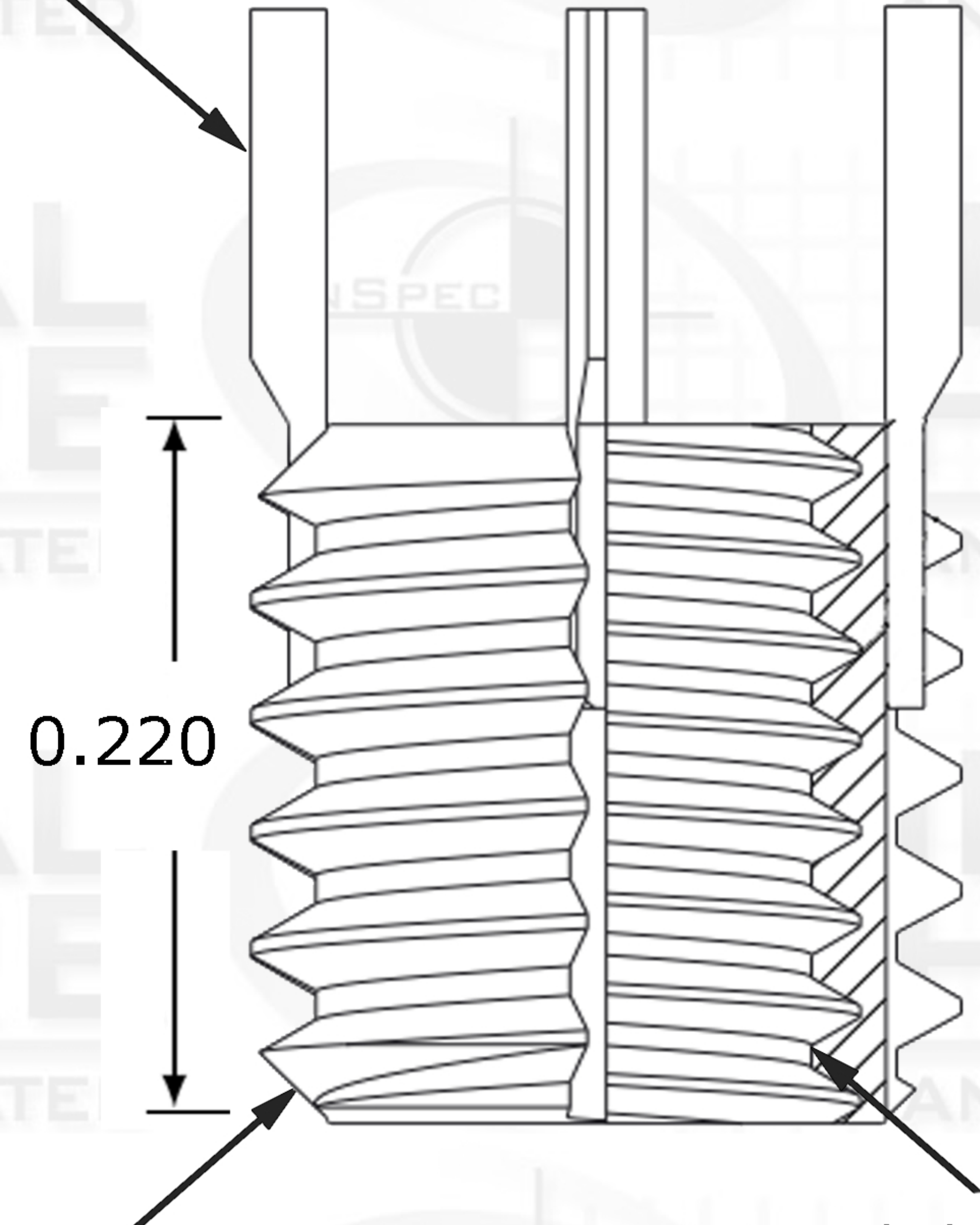

Key



0.220

External Thread Pitch
1/4-28

Internal Thread Pitch
8-32

Suggested Drill Bit Size



0.2280 (#1)

PROPRIETARY AND CONFIDENTIAL

THIS DRAWING AND IT'S CONTENT IS THE SOLE PROPERTY OF INDUSTRIAL HARDWARE & SPECIALTIES,INC.. ANY REPRODUCTION IN PART OR AS A WHOLE WITHOUT THE WRITTEN PERMISSION OF INDUSTRIAL HARDWARE & SPECIALTIES,INC. IS STRICTLY PROHIBITED.

		Internal	NAME	DATE
		TH. STANDARD: ANSI/ASME	DRAWN	
		ACRONYM: UNC	CHECKED	
		ROTATION: Right-Hand	ENG APPR.	
		External	MFG APPR.	
		TH. STANDARD: ANSI/ASME	Q.A.	
		ACRONYM: UNF		
		ROTATION: Right-Hand		
		MATERIAL FINISH		
		Stainless Steel Type A286		
NEXT ASSY	USED ON	PART NUMBER	COMMENTS:	
		35L8C-7R1P-08		
APPLICATION		DO NOT SCALE DRAWING		



17-B KENTUCKY AVENUE
PATERSON, NEW JERSEY 07503
TEL: 973-684-4010 FAX: 973-684-3095
email: TechSupport@industrialhardware.com
www.industrialhardware.com

SIZE	DWG. NO.	REV.
A		
SCALE:1:8	WEIGHT:	SHEET 1 OF 1