

# Key-Locking Non-Locking

REVISIONS		DATE	APPROVED
ZONE	REV.	DESCRIPTION	

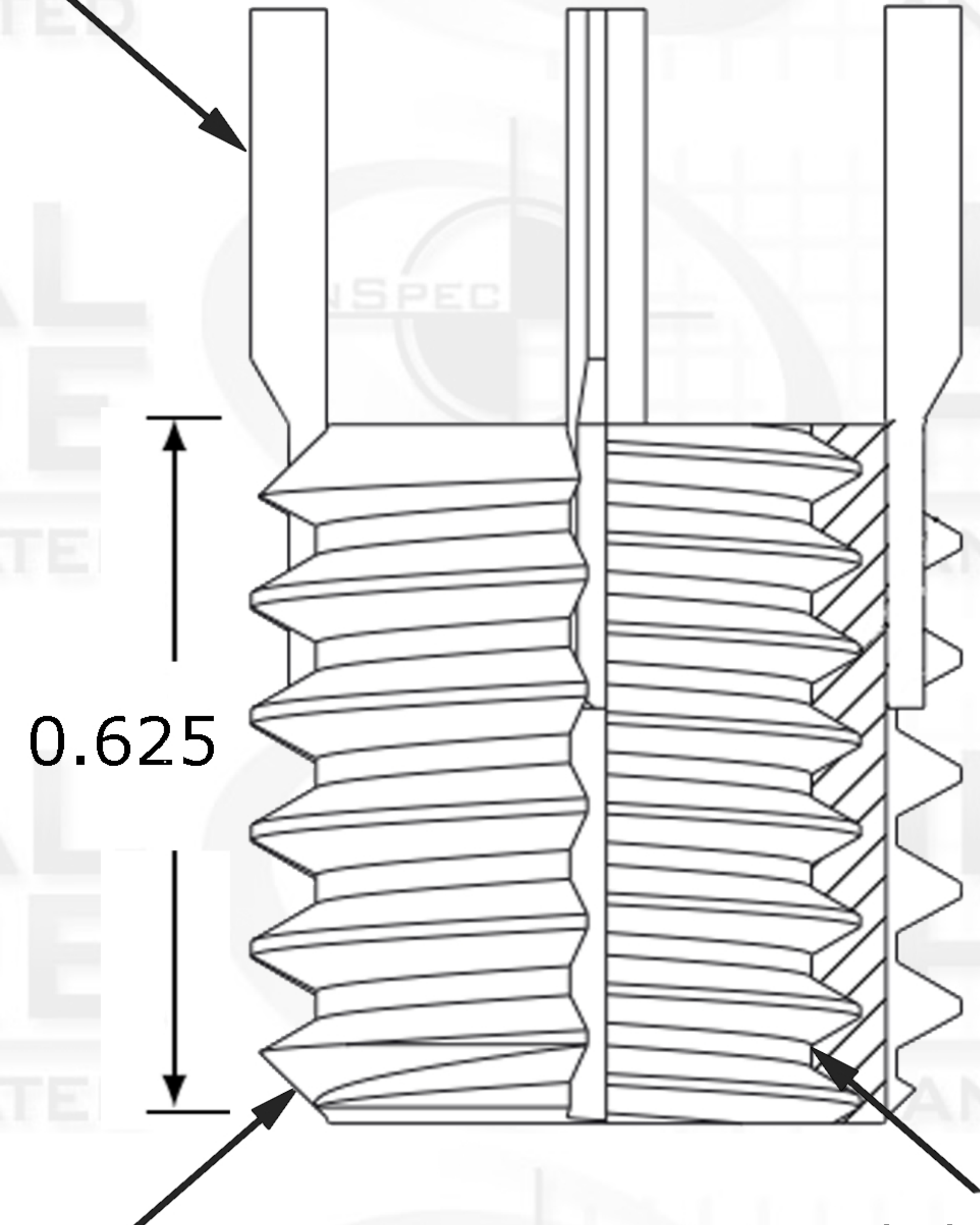

Key



0.625

External Thread Pitch  
5/8-11

Internal Thread Pitch  
1/2-20

Suggested Drill Bit Size



0.5782 (37/64)

## PROPRIETARY AND CONFIDENTIAL

THIS DRAWING AND IT'S CONTENT IS THE SOLE PROPERTY OF INDUSTRIAL HARDWARE & SPECIALTIES,INC.. ANY REPRODUCTION IN PART OR AS A WHOLE WITHOUT THE WRITTEN PERMISSION OF INDUSTRIAL HARDWARE & SPECIALTIES,INC. IS STRICTLY PROHIBITED.

		<b>Internal</b>	NAME	DATE
		TH. STANDARD: ANSI/ASME	DRAWN	
		ACRONYM: UNF	CHECKED	
		ROTATION: Right-Hand	ENG APPR.	
		<b>External</b>	MFG APPR.	
		TH. STANDARD: ANSI/ASME	Q.A.	
		ACRONYM: UNC		
		ROTATION: Right-Hand		
		MATERIAL FINISH		
		Stainless Steel Type A286		
NEXT ASSY	USED ON	PART NUMBER	COMMENTS:	
		35L8C-7Q2Y-50-05		
APPLICATION		DO NOT SCALE DRAWING		



**17-B KENTUCKY AVENUE**  
**PATERSON, NEW JERSEY 07503**  
**TEL: 973-684-4010 FAX: 973-684-3095**  
**email: TechSupport@industrialhardware.com**  
**www.industrialhardware.com**

SIZE	DWG. NO.	REV.
<b>A</b>		
SCALE:1:8	WEIGHT:	SHEET 1 OF 1