

Key-Locking Non-Locking

ZONE		REV.	REVISIONS	DATE	APPROVED
			DESCRIPTION		

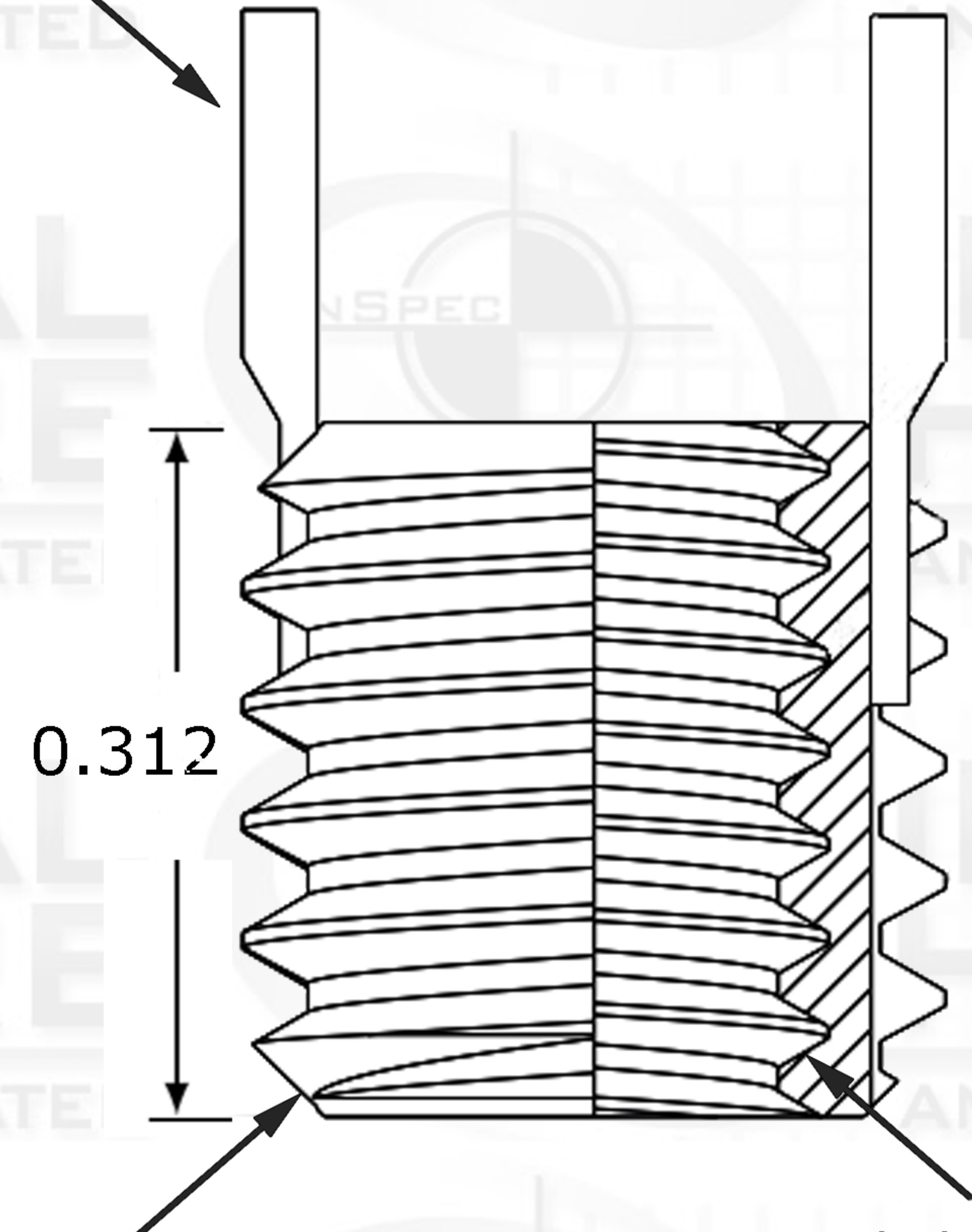

Key



0.312

External Thread Pitch
3/8-16

Internal Thread Pitch
10-24

Suggested Drill Bit Size



0.3320 (Letter Q)

PROPRIETARY AND CONFIDENTIAL

THIS DRAWING AND IT'S CONTENT IS THE SOLE PROPERTY OF INDUSTRIAL HARDWARE & SPECIALTIES,INC.. ANY REPRODUCTION IN PART OR AS A WHOLE WITHOUT THE WRITTEN PERMISSION OF INDUSTRIAL HARDWARE & SPECIALTIES,INC. IS STRICTLY PROHIBITED.

		Internal		NAME	DATE
		TH. STANDARD: ANSI/ASME	DRAWN		
		ACRONYM: UNC	CHECKED		
		ROTATION: Right-Hand	ENG APPR.		
		External	MFG APPR.		
		TH. STANDARD: ANSI/ASME	Q.A.		
		ACRONYM: UNC			
		ROTATION: Right-Hand			
		MATERIAL FINISH	COMMENTS:		
		Stainless Steel Type 303			
NEXT ASSY	USED ON	PART NUMBER			
		35L8C-686C-10-0A			
APPLICATION		DO NOT SCALE DRAWING			



**17-B KENTUCKY AVENUE
PATERSON, NEW JERSEY 07503
TEL: 973-684-4010 FAX: 973-684-3095
email: TechSupport@industrialhardware.com
www.industrialhardware.com**

SIZE	DWG. NO.	REV.
A		
SCALE:1:8	WEIGHT:	SHEET 1 OF 1