

# Key-Locking Non-Locking

ZONE		REV.	REVISIONS	DATE	APPROVED
			DESCRIPTION		

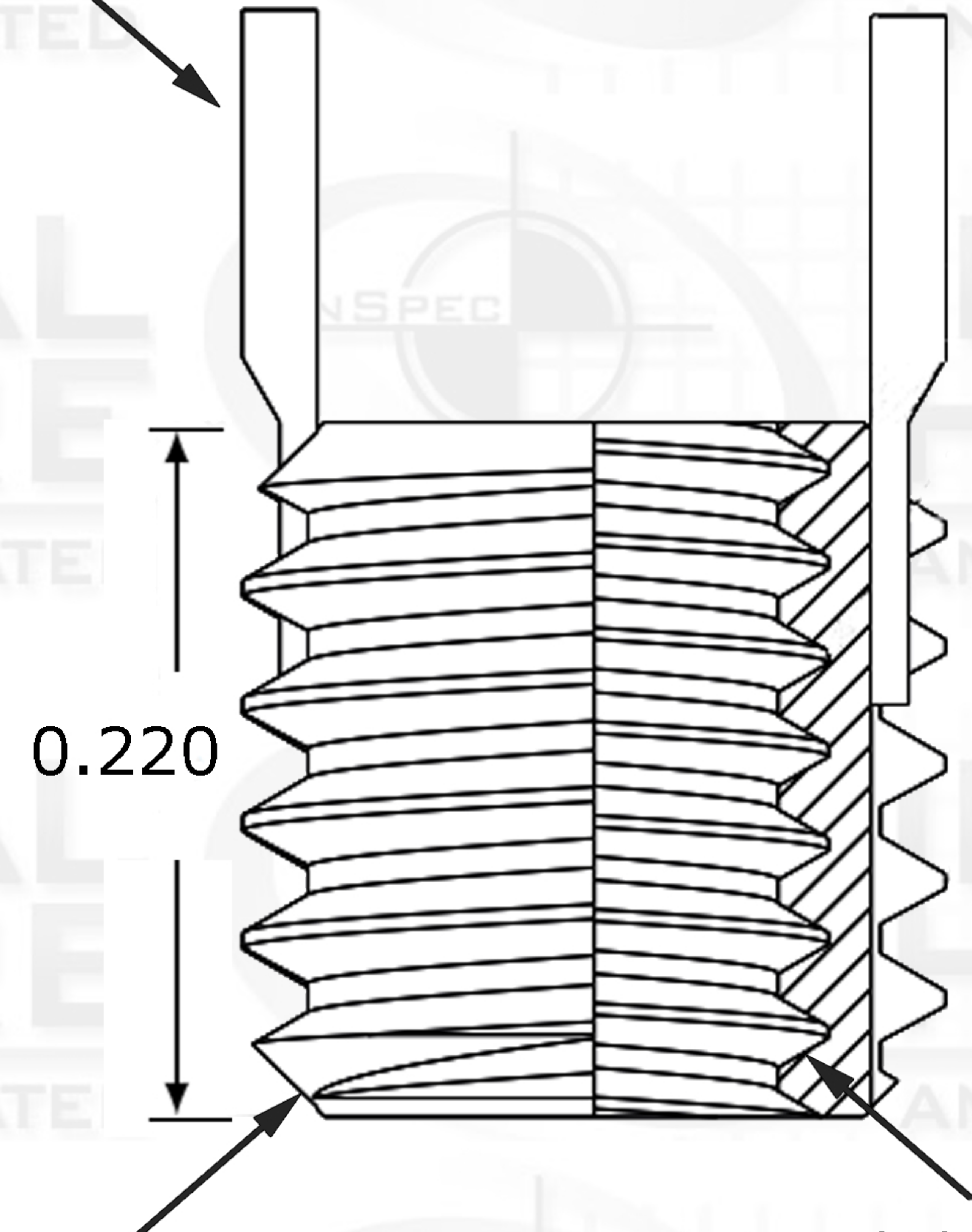

Key



0.220

External Thread Pitch  
1/4-28

Internal Thread Pitch  
8-32

Suggested Drill Bit Size



0.2280 (#1)

## PROPRIETARY AND CONFIDENTIAL

THIS DRAWING AND IT'S CONTENT IS THE SOLE PROPERTY OF INDUSTRIAL HARDWARE & SPECIALTIES,INC.. ANY REPRODUCTION IN PART OR AS A WHOLE WITHOUT THE WRITTEN PERMISSION OF INDUSTRIAL HARDWARE & SPECIALTIES,INC. IS STRICTLY PROHIBITED.

		<b>Internal</b>		NAME	DATE
		TH. STANDARD: ANSI/ASME	DRAWN		
		ACRONYM: UNC	CHECKED		
		ROTATION: Right-Hand	ENG APPR.		
		<b>External</b>	MFG APPR.		
		TH. STANDARD: ANSI/ASME	Q.A.		
		ACRONYM: UNF			
		ROTATION: Right-Hand			
		MATERIAL FINISH			
		Stainless Steel Type 303	COMMENTS:		
NEXT ASSY	USED ON	PART NUMBER			
		35L8C-6776-08-0A			
APPLICATION		DO NOT SCALE DRAWING			



17-B KENTUCKY AVENUE  
PATERSON, NEW JERSEY 07503  
TEL: 973-684-4010 FAX: 973-684-3095  
email: TechSupport@industrialhardware.com  
www.industrialhardware.com

SIZE	DWG. NO.	REV.
A		
SCALE:1:8	WEIGHT:	SHEET 1 OF 1