

# Key-Locking Non-Locking

REVISIONS		DATE	APPROVED
ZONE	REV.	DESCRIPTION	

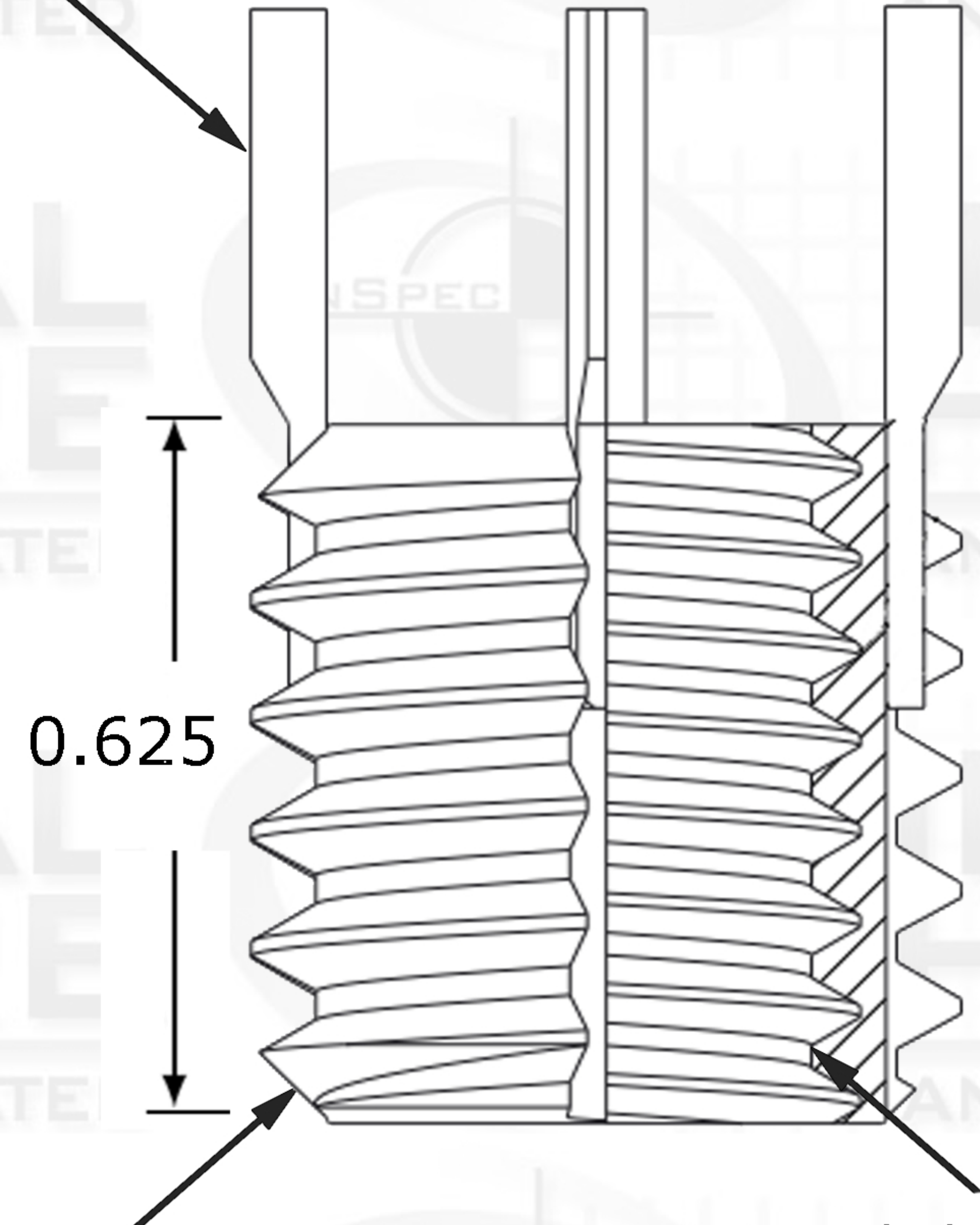

Key



0.625

External Thread Pitch  
11/16-11

Internal Thread Pitch  
7/16-14

Suggested Drill Bit Size

0.6407 (41/64)



## PROPRIETARY AND CONFIDENTIAL

THIS DRAWING AND IT'S CONTENT IS THE SOLE PROPERTY OF INDUSTRIAL HARDWARE & SPECIALTIES,INC.. ANY REPRODUCTION IN PART OR AS A WHOLE WITHOUT THE WRITTEN PERMISSION OF INDUSTRIAL HARDWARE & SPECIALTIES,INC. IS STRICTLY PROHIBITED.

		<b>Internal</b>	NAME	DATE
		TH. STANDARD: ANSI/ASME	DRAWN	
		ACRONYM: UNC	CHECKED	
		ROTATION: Right-Hand	ENG APPR.	
		<b>External</b>	MFG APPR.	
		TH. STANDARD: ANSI/ASME	Q.A.	
		ACRONYM: 11NS		
		ROTATION: Right-Hand		
		MATERIAL FINISH	COMMENTS:	
		Alloy Steel Type 4140		
NEXT ASSY	USED ON	PART NUMBER		
		35L8C-37GR-43-05		
APPLICATION		DO NOT SCALE DRAWING		



**17-B KENTUCKY AVENUE**  
**PATERSON, NEW JERSEY 07503**  
**TEL: 973-684-4010 FAX: 973-684-3095**  
**email: TechSupport@industrialhardware.com**  
**www.industrialhardware.com**

SIZE	DWG. NO.	REV.
<b>A</b>		
SCALE:1:8	WEIGHT:	SHEET 1 OF 1