

Key-Locking Non-Locking

| ZONE | | REV. | REVISIONS | DATE | APPROVED |
|------|--|------|-------------|------|----------|
| | | | DESCRIPTION | | |
| | | | | | |

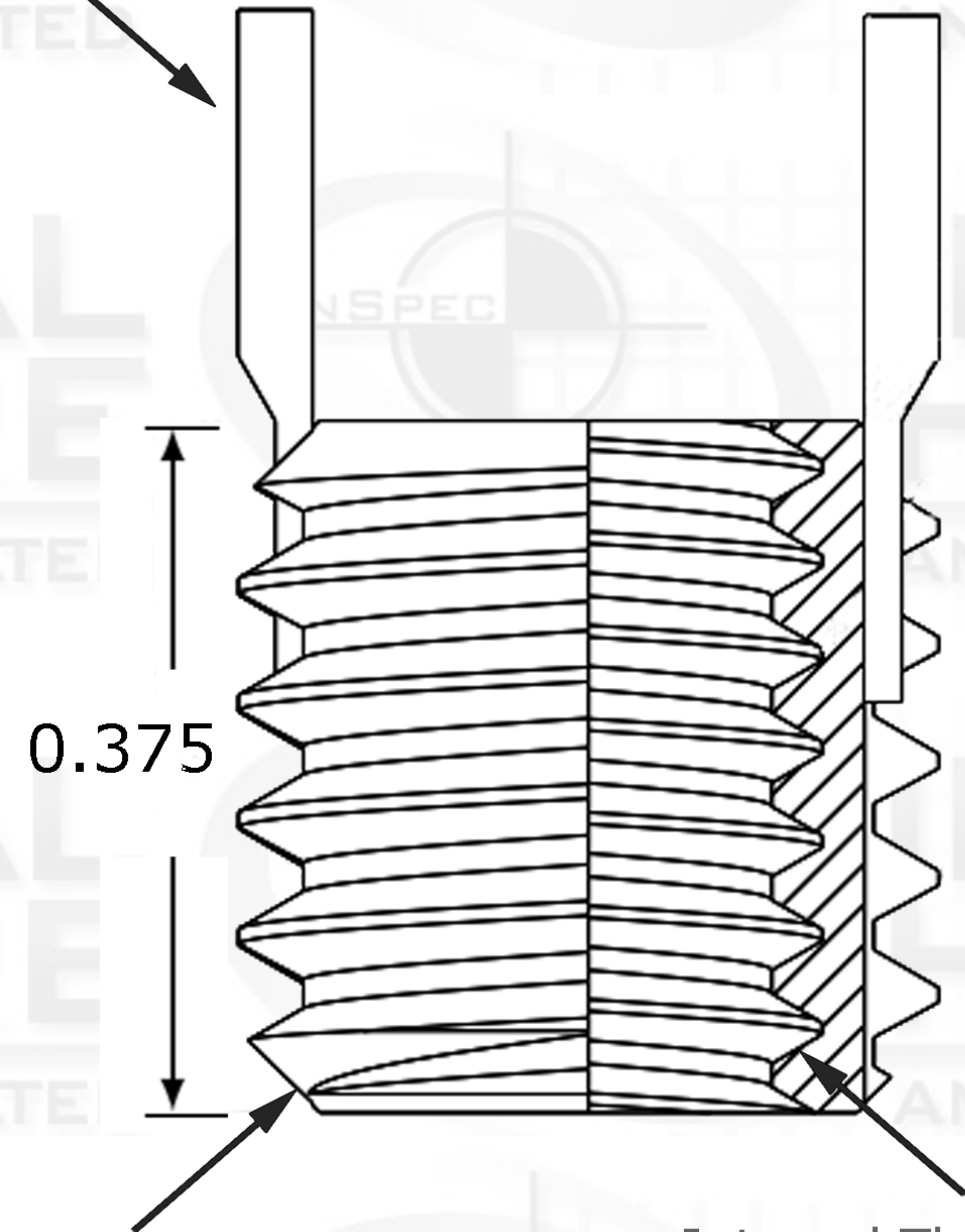

Key



0.375

External Thread Pitch
1/2-13

Internal Thread Pitch
1/4-20

Suggested Drill Bit Size



0.4532 (29/64)

PROPRIETARY AND CONFIDENTIAL

THIS DRAWING AND IT'S CONTENT IS THE SOLE PROPERTY OF INDUSTRIAL HARDWARE & SPECIALTIES,INC.. ANY REPRODUCTION IN PART OR AS A WHOLE WITHOUT THE WRITTEN PERMISSION OF INDUSTRIAL HARDWARE & SPECIALTIES,INC. IS STRICTLY PROHIBITED.

| | | | | | |
|-------------|---------|-------------------------|--|-----------|------|
| | | Internal | | NAME | DATE |
| | | TH. STANDARD: ANSI/ASME | | DRAWN | |
| | | ACRONYM: UNC | | CHECKED | |
| | | ROTATION: Right-Hand | | ENG APPR. | |
| | | External | | MFG APPR. | |
| | | TH. STANDARD: ANSI/ASME | | Q.A. | |
| | | ACRONYM: UNC | | | |
| | | ROTATION: Right-Hand | | | |
| | | MATERIAL FINISH | | | |
| | | Alloy Steel Type 4140 | | | |
| NEXT ASSY | USED ON | PART NUMBER | | COMMENTS: | |
| | | 35L8C-37GM-25-05 | | | |
| APPLICATION | | DO NOT SCALE DRAWING | | | |



17-B KENTUCKY AVENUE
PATERSON, NEW JERSEY 07503
TEL: 973-684-4010 FAX: 973-684-3095
email: TechSupport@industrialhardware.com
www.industrialhardware.com

| | | |
|-----------|----------|--------------|
| SIZE | DWG. NO. | REV. |
| A | | |
| SCALE:1:8 | WEIGHT: | SHEET 1 OF 1 |