

## 9675 Series and 9676 Series

Heavy Duty Aluminum  
Double Box Track and Hardware  
for doors 1-3/8" to 1-3/4" thick

### Notes:

- Grooved fascia for painting

### Additional Notes:

- Interchanges with:
- Stanley 1755, 40-3664, 40-3855/BP150
  - Johnson 134F/138F
  - Grant 7000 Series
  - Cox 15-220 Series
  - Lawrence 581 Track, HD520 Hardware

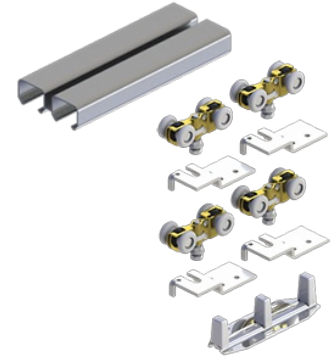

## PRODUCT SPECIFICATIONS

### BY-PASS SETS:

- 9675-48 = For two 24" (610 mm) doors
- 9675-60 = For two 30" (762 mm) doors
- 9675-72 = For two 36" (914 mm) doors
- 9675-96 = For two 48" (1219 mm) doors

### ALUMINUM DOUBLE BOX TRACK:

- 9602-46 = 46" (1168 mm)
- 9602-58 = 58" (1473 mm)
- 9602-70 = 70" (1778 mm)
- 9602-94 = 94" (2388 mm)
- 9602-118 = 118" (2997 mm)
- 9602-142 = 142" (3607 mm)

### ALUMINUM FASCIA:

- 9709-72 = 72" (1829 mm) 2-3/4" (70 mm)
- 9709-96 = 96" (2438 mm) 2-3/4" (70 mm)

### PARTS BAG:

- 9679 = 125 lb (57 kg); 4 each 9605 Hanger and 9610 Top Mount Plate, 1 each 9909 Guide

## PRODUCT SIZE OPTIONS

PART #	DESCRIPTION
9675-48	By-Pass Set for two 24 Inch (610mm) Doors
9675-60	By-Pass Set for two 30 Inch (762mm) Doors
9675-72	By-Pass Set for two 36 Inch (914mm) Doors
9675-96	By-Pass Set for two 48 Inch (1219mm) Doors