

# Bi-Fold



Hager Companies Bi-Fold (by-fold) door hardware is, the smoother the operation of your doors will be—over the lifetime of the installation. Contractors, specification writers and architects insist on Hager's hardware sets and components to ensure trouble-free installation and reliable performance.

Hager offers a wide range of classic Bi-Fold door hardware sets featuring heavy-duty aluminum tracks in 2- and 4-door configurations. Our tracks accommodate rough openings from three to eight feet and support doors up to 125 lbs.

**FOR ANY HAGER PURCHASE CONTACT INDUSTRIAL HARDWARE & SPECIALTIES INC.  
CALL 1800-684-4010**



2016  
[www.hagerco.com](http://www.hagerco.com)



## BI-FOLD - 9570 TRACK

### FEATURES

- Standard duty aluminum box track and hardware
- Conforms to ANSI A156.14
- Type: D8621, D8642, D8652, D8662

### SPECIFICATIONS

- For doors 1-1/8" (28.6 mm - 44 mm) to 1-3/4" (44 mm) thick
- Up to 50 lbs (57 kg) per panel bi-fold
- Up to 30 lbs (34 kg) per panel multi-fold
- Track is extruded aluminum jump-proof style with "V" shaped rails
- Hangers have four 7/8" (22 mm) diameter wheels
- Top and bottom pivots are heavy duty with solid brass bottom socket assembly for smooth, long lasting operation
- Note: Loose pin full mortise hinges 1741/1279 are recommended – not included (3 required for 9162, 6 required for 9164)

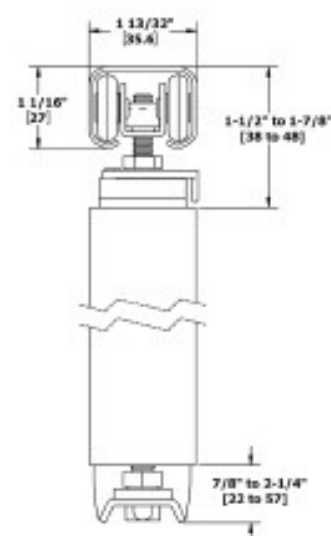

Optional Bottom Track  
9121 - 9122

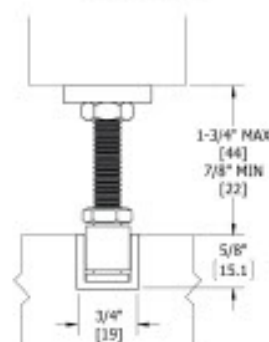

Installation note: Clearance between door bottom and top of 9122 track must be 7/8" (22 mm) minimum to 1-3/4" (44 mm) maximum.

Part Number	Description
9570 Series Set - For two doors Includes one (1) 9601 track and one (1) 9571 parts bag	
9570-36	Bi-Fold Set - 3' (914 mm) opening for two 18" (457 mm) doors
9570 Series Set - For four doors Includes one (1) 9601 track and two (2) 9571 parts bag	
9570-48	Bi-Fold Set - 4' (1219 mm) opening for four 12" (305 mm) doors
9570-60	Bi-Fold Set - 5' (1524 mm) opening for four 15" (381 mm) doors
9570-72	Bi-Fold Set - 6' (1829 mm) opening for four 18" (457 mm) doors
9570-96	Bi-Fold Set - 8' (2438 mm) opening for four 24" (610 mm) doors

**TRACKS** - 0.050" (1.3 mm) thick aluminum

Part Number	Description
Tracks for use with 9570 Series	
9601-35	35" (889 mm) Aluminum Box Track
9601-47	47" (1194 mm) Aluminum Box Track
9601-59	59" (1499 mm) Aluminum Box Track
9601-63	63" (1600 mm) Aluminum Box Track
9601-71	71" (1803 mm) Aluminum Box Track
9601-96	96" (2438 mm) Aluminum Box Track
9601-120	120" (3048 mm) Aluminum Box Track
9601-144	144" (3658 mm) Aluminum Box Track

FOR ANY HAGER PURCHASE CONTACT INDUSTRIAL HARDWARE & SPECIALTIES INC.  
CALL 1800-684-4010



## BI-FOLD - 9570 TRACK COMPONENTS



### 9601

#### Aluminum Box Track

- Materials: Extruded aluminum  
 Gauge: 0.050" (1.3 mm)  
 Track: 1-1/16" x 1-3/8"  
 (27 mm x 35 mm)  
 Lengths: 35" (889 mm) to 144"  
 (2657 mm)  
 Notes:
- Refer to series pages for weight capacities
  - Jump proof twin channel design



### 9559

#### Aligner

- Materials: Steel with brass-tone dichromate finish  
 Notes:
- Keeps lead doors aligned when closed
  - Use one on each lead door



### 9571

#### Parts Bag

- Includes one (1) 9572 hanger, one (1) 9618 pivot set, one (1) 9559 aligner, one (1) 9558 knob, and one (1) 9815 bumper stop



### 9815

#### Bumper Stop

- Materials: Zinc plated steel and rubber  
 Notes:
- Fits all Hager track styles except 9101
  - Screws onto track
  - Included in bi-fold sets 9570 and 9890



### 9572

#### Four Wheel Hanger with Top Mount Plate

- Materials: Steel with brass-tone dichromate finish  
 Wheel: 7/8" (22 mm) diameter  
 Notes:
- Wheels are self aligning to allow consistent contact with track
  - Pre-lubricated Celcon wheels
  - Includes wrench
  - For use on doors weighing up to 100 lbs (45 kg) each
  - For use with 9601, 9602, and 9603 track



### Optional Part Bags

#### 9569 Parts Bag

- Includes one (1) 9572 hanger, one (1) 9618 pivot set, one (1) 9559 aligner, one (1) 9558 knob, one (1) 9815 bumper stop, and three (3) 9220 hinges



### 9618

#### Pivot Set

- Materials: Zinc plated steel  
 Notes:
- For doors up to 50 lbs (23 kg)
  - Thumb wheel vertical adjustment
  - Top and bottom pivots require 3/8" (10 mm) diameter holes
  - For use with 9601



### 9220

#### Bi-Fold Door Hinge

- Materials: Steel with dichromate zinc finish  
 Hinge: 3" x 1" (76 mm x 25 mm) hole  
 Hole Locations: 1/2" (13 mm) from the center lines of holes to center of barrel  
 Notes: Non-mortise and easy to install



### 9558

#### Wood Knob

- Diameter: 1-1/2" (38 mm)  
 Materials: Solid wood  
 Notes: Will accept paint or stain

### Optional Components

- 9121 Adj. Bottom Door Guide  
 9122 Bottom Guide Channel

For optional components see pages 59-63

FOR ANY HAGER PURCHASE CONTACT INDUSTRIAL HARDWARE & SPECIALTIES INC.







## BI-FOLD - 9860 & 9861 BI-FOLD SETS

### FEATURES

- Heavy duty aluminum box track and hardware
- Conforms to ANSI A156.14
- Type: D8621, D8641, D8651, D8661

### SPECIFICATIONS

- For doors 1-3/8" - 1-3/4" (35 mm - 44 mm) thick
- Up to 125 lbs (57 kg) per panel bi-fold
- Up to 75 lbs (34 kg) per panel multi-fold
- Quick release hangers allow easy door hanging and removal
- Universal extruded aluminum track interchanges with Stanley & Johnson track and hangers
- Hangers have 1" (25 mm) diameter wheels

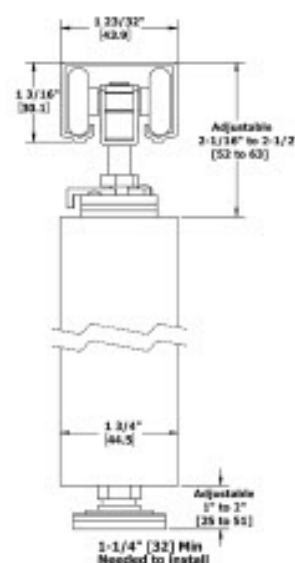

Interchanges with Stanley 125/250 Series and Johnson 100 Series.

Part Number	Description
<b>9860 Bi-Fold Set - For two doors</b>	
Includes one (1) 9821 track, one (1) 9894 parts bag, and three (3) 1741 3.5" x 3.5" US2D hinges	
9860-30	Bi-Fold Set - 30" (762 mm) opening for two doors
9860-36	Bi-Fold Set - 36" (914 mm) opening for two doors
9860-48	Bi-Fold Set - 48" (1219 mm) opening for two doors
<b>9861 Bi-Fold Set - For four doors</b>	
Includes one (1) 9821 track, two (2) 9894 parts bags, and six (6) 1741 3.5" x 3.5" US2D hinges	
9861-48	Bi-Fold Set - 48" (1219 mm) opening for four doors
9861-60	Bi-Fold Set - 60" (1524 mm) opening for four doors
9861-72	Bi-Fold Set - 72" (1829 mm) opening for four doors
9861-96	Bi-Fold Set - 96" (2438 mm) opening for four doors

**TRACKS** - 0.06" (1.5 mm) thick aluminum

Part Number	Description
Tracks for use with 9800 Series	
9821-59	59" (1499 mm) Heavy Duty Aluminum Box Track
9821-71	71" (1803 mm) Heavy Duty Aluminum Box Track
9821-96	96" (2438 mm) Heavy Duty Aluminum Box Track
9821-144	144" (3658 mm) Heavy Duty Aluminum Box Track

Optional Bottom Track  
9121 - 9122

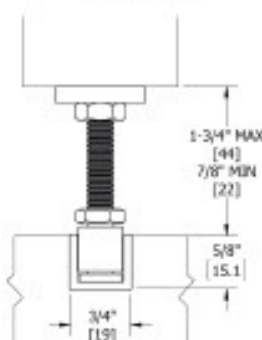

Installation note: Clearance between door bottom and top of 9122 track must be 7/8" (22 mm) minimum to 1-3/4" (44 mm) maximum.

FOR ANY HAGER PURCHASE CONTACT INDUSTRIAL HARDWARE & SPECIALTIES INC.  
CALL 1800-684-4010



## BI-FOLD - 9860 & 9861 TRACK COMPONENTS



### 9821

#### Aluminum Box Track

- Materials: Extruded aluminum  
 Gauge: 0.06" (1.55 mm)  
 Track: 1-5/8" x 1-1/16"  
 (41 x 27 mm)
- Lengths: 59" (1499 mm) to 144" (3658 mm)
- Notes:
- For doors up to 250 lbs (113 kg)
  - Jump proof twin channel design



### 9828

#### Bi-Fold Pivot Set

- Materials: Zinc plated steel
- Notes:
- For doors up to 125 lbs (57 kg)
  - Track pivot bearing mounts up inside track - no track cutting required
  - Bottom pivot socket has ball bearing raceway
  - Top and bottom pivots require 1/2" (13 mm) diameter and 1-3/4" (44 mm) deep holes
  - For use with 9801 and 9821 track



### 9894

#### Parts Bag

Includes one (1) 9825 4-wheel ball bearing hanger with quick release top mount plate, one (1) 9559 aligner, one (1) 9828 bi-fold pivot set with one (1) 9815 bumper stop



### 9815

#### Bumper Stop

- Materials: Zinc plated steel and rubber
- Notes:
- Fits all Hager track styles except 9101
  - Screws onto track
  - Included in bi-fold sets 9570 and 9890



### 9825

#### Four Wheel Ball Bearing Quick Release Hanger

- Materials: Zinc plated steel
- Wheels: Self aligning to allow consistent contact with track
- Wheel: 1" (25 mm) diameter
- Notes:
- For doors up to 125 lbs (57 kg) for bi-fold applications
  - Pre-lubricated Celcon wheels
  - For use with 9821 track
  - Quick release feature allows easy door hanging and removal



### 9559

#### Aligner

- Materials: Steel with brass-tone dichromate finish
- Notes:
- Keeps lead doors aligned when closed
  - Use one on each lead door

### Optional Components

- |      |                        |
|------|------------------------|
| 1741 | Full Mortise Hinge     |
| 9220 | Bi-Fold Hinge          |
| 9121 | Adj. Bottom Door Guide |
| 9122 | Bottom Guide Channel   |
| 9558 | Wood Knob              |

For optional components see pages 59-63

FOR ANY HAGER PURCHASE CONTACT INDUSTRIAL HARDWARE & SPECIALTIES INC.





## BI-FOLD - 9890 & 9891 PACKAGED SETS

### FEATURES

- Heavy duty aluminum box track and hardware
- Conforms to ANSI A156.14
- Type: D8621, D8641, D8651, D8661

### SPECIFICATIONS

- For doors 1-1/8" - 1-3/4" (29 mm - 44 mm) thick
- Quick release hanger allows easy door hanging and removal
- Up to 125 lbs (57 kg) per panel bi-fold
- Up to 75 lbs (34 kg) per panel multi-fold
- Track is extruded aluminum jump-proof style with "V" shaped rails
- Hangers have four 1-1/4" (32 mm) diameter wheels
- Top and bottom pivots are heavy duty with ball bearing bottom socket assembly for smooth, long lasting operation
- Note: 9890 Series requires 1741 loose pin hinges – included

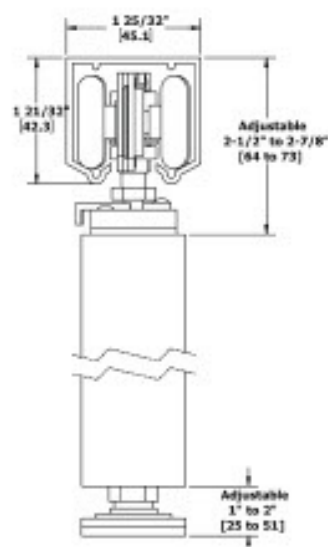

Optional Bottom Track  
9121 - 9122

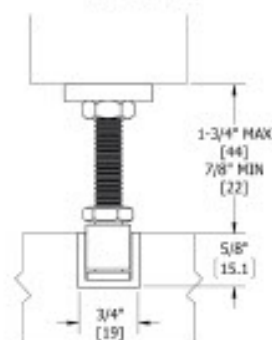

Installation note: Clearance between door bottom and top of 9122 track must be 7/8" (22 mm) minimum to 1-3/4" (44 mm) maximum.

Part Number	Description
9890 Series Set - For two doors Includes one (1) 9801 track, one (1) 9827 hanger, one (1) 9828 pivot, and three (3) 1741 3.5" x 3.5" US2D hinges	
9890-30	Bi-Fold Set - 30" (762 mm) opening for two doors
9890-36	Bi-Fold Set - 36" (914 mm) opening for two doors
9890-48	Bi-Fold Set - 48" (1219 mm) opening for two doors
9891 Series Set - For four doors Includes one (1) 9801 track, one (1) 9827 hanger, one (1) 9828 pivot, and six (6) 1741 3.5" x 3.5" US2D hinges	
9891-48	Bi-Fold Set - 48" (1219 mm) opening for four doors
9891-60	Bi-Fold Set - 60" (1524 mm) opening for four doors
9891-72	Bi-Fold Set - 72" (1829 mm) opening for four doors
9891-96	Bi-Fold Set - 96" (2438 mm) opening for four doors

**TRACKS** - 0.075" (1.9 mm) thick aluminum

Part Number	Description
Tracks for use with 9890 Series	
9801-72	72" (1829 mm) Aluminum Box Track
9801-96	96" (2438 mm) Aluminum Box Track
9801-120	120" (3048 mm) Aluminum Box Track
9801-144	144" (3658 mm) Aluminum Box Track
9801-192	192" (4877 mm) Aluminum Box Track

FOR ANY HAGER PURCHASE CONTACT INDUSTRIAL HARDWARE & SPECIALTIES INC.  
CALL 1800-684-4010





## BI-FOLD - 9890 & 9891 TRACK COMPONENTS



### 9801

#### Heavy Duty Aluminum Box Track

- Materials: Extruded aluminum  
 Gauge: 0.075" (1.9 mm)  
 Track: 1-5/8" x 1-3/4"  
 (41 mm x 44 mm)  
 Lengths: 72" (1829 mm) to 192"  
 (4877 mm)  
 Notes:
  - For doors up to 250 lbs (113 kg)
  - Jump proof twin channel design



### 9828

#### Bi-Fold Pivot Set

- Materials: Zinc plated steel  
 Notes:
  - For doors up to 125 lbs (57 kg)
  - Track pivot bearing mounts up inside track - no track cutting required
  - Bottom pivot socket has ball bearing raceway
  - Top and bottom pivots require 1/2" (13 mm) diameter and 1-3/4" (44 mm) deep holes
  - For use with 9801 and 9821 track



### 1741

#### Full Mortise, Five Knuckle, Plain Bearing Hinge

- Steel with steel pin (ANSI A5134)
- Reversible
- Square corners
- Removable pin
- 3-1/2" x 3-1/2" (89 mm x 89 mm)
- US2D



### 9559

#### Aligner

- Materials: Steel with brass-tone dichromate finish  
 Notes:
  - Keeps lead doors aligned when closed
  - Use one on each lead door



### 9827

#### Four Wheel Ball Bearing Quick Release Hanger

- Materials: Zinc plated steel  
 Wheels: Self aligning to allow consistent contact with track  
 Wheel: 1-1/4" (32 mm) diameter  
 Notes:
  - For doors up to 125 lbs (57 kg)
  - Pre-lubricated Celcon wheels
  - Ball bearing axles
  - For doors up to 250 lbs (113 kg) for by-pass and pocket applications
  - For use with 9801 track
  - Quick release feature allows easy door hanging and removal



### 9815

#### Bumper Stop

- Materials: Zinc plated steel and rubber  
 Notes:
  - Fits all Hager track styles except 9101
  - Screws onto track
  - Included in bi-fold sets 9570 and 9890

### Optional Components

- |      |                        |
|------|------------------------|
| 9121 | Adj. Bottom Door Guide |
| 9122 | Bottom Guide Channel   |
| 9566 | Knob                   |
| 9567 | Rose                   |
| 9558 | Wood Knob              |

FOR ANY HAGER PURCHASE CONTACT INDUSTRIAL HARDWARE & SPECIALTIES INC.

For optional components see pages 59-63

